

Rám s nádržkou určený do sádkokartonových konstrukcí, pro zabudování suchým procesem, pro uchycení závěsného WC
Mounting frame with concealed tank for wall hung toilets, for installation to the plasterboard

(CS) Montážní návod (RU) Инструкция по монтажу (RO) Instrucțiuni de montaj (NL) Montage instructie
 (SK) Montážny návod (DE) Montageanleitung (ES) Manual de instrucciones (LT) Montavimo instrukcija
 (EN) Mounting instructions (PL) Instrukcja montażu (FR) Notice de montage (HU) Szerelési útmutató

(CS) Specifikace dodávky (RU) Спецификация поставки (RO) Componente livrate (NL) Leveringsomvang
 (SK) Špecifikácia dodávky (DE) Lieferumfang (ES) Especificación de suministro (LT) Tiekimo specifikacija
 (EN) Supplied equipment (PL) Specyfikacja dostawy (FR) Equipements fournis (HU) Tartozékok

SLR 21A - Obj. č. (Code Nr.) - 08212

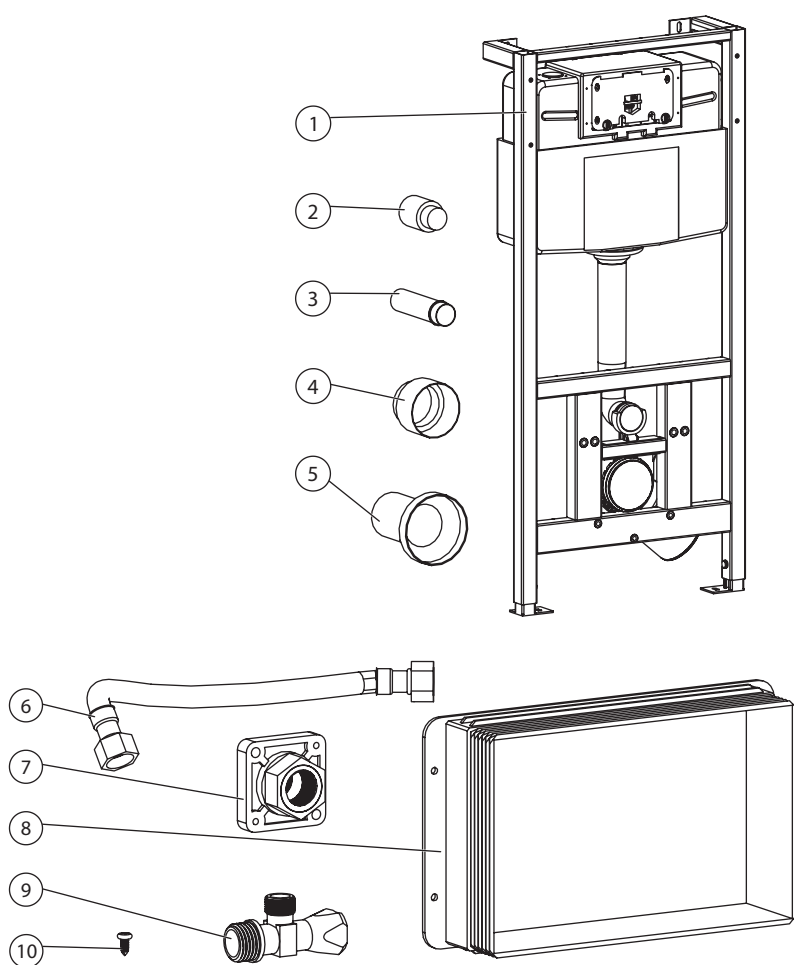

Pozice / Position	Obj. číslo / Order num.	Počet / Quantity	Poznámky / Note
1	47580	1	
2		1	
3		1	
4		1	
5		1	
6		1	
7		1	
8		1	
9		1	
10		8	
11		4	Ø 12
12		4	8X70
13		5	
14		2	M12
15		3	M10
16		2	
17		2	
18		2	M12
19		4	M12
20		3	M10
21		8	Ø 8,4
22		3	Ø 10,5
23		1	
24		2	M8X16
25	50954	2	
26	50955	2	
27		4	M8X30
28	4	Ø 8	
29	50392	8	Ø 10
30	50391	4	M10
31	50393	4	M10X25

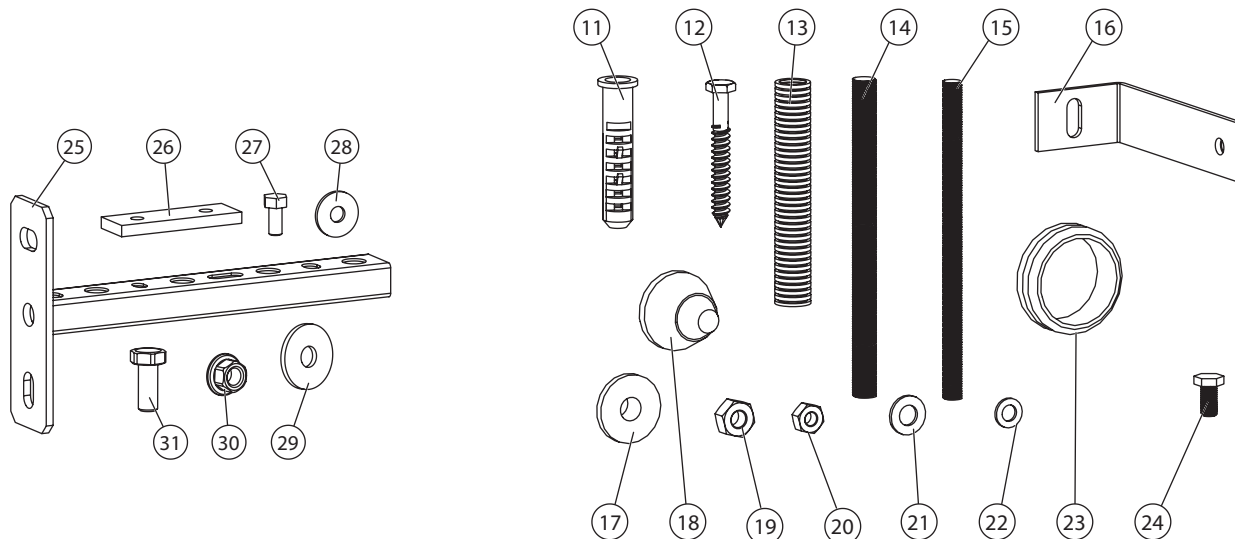

CS Rozměry
SK Rozměry
EN Dimensions

RU Размеры
DE Abmessungen
PL Rozmiary

RO Dimensiuni
ES Dimensiones
FR Dimensions

NL Afmetingen
LT Dydis
HU Méretek

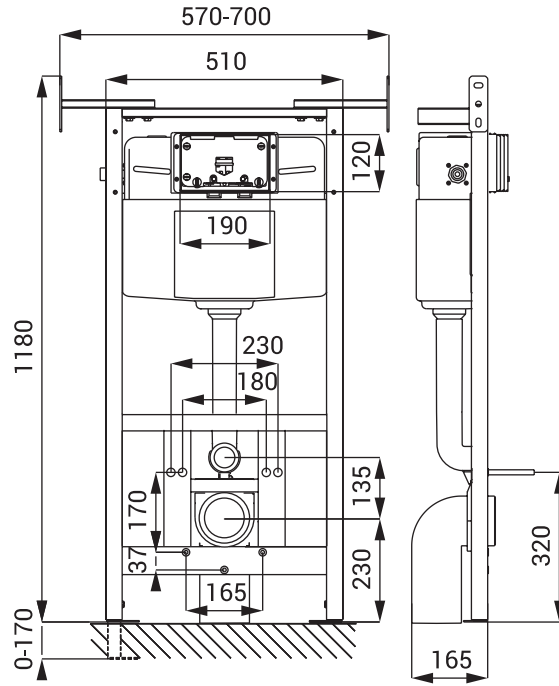

CS Instalace
SK Inštalácia
EN Installation

RU Схема включения и монтажа
DE Installation
PL Instalacja

RO Instalare
ES Instalación
FR Installation

NL Installatie
LT Montavimo ir įjungimo schema
HU Beüzemelés

1. PŘED INSTALACÍ JE NUTNÉ ZKONTROLOVAT TĚSNOST NÁDRŽE.
2. PŘED PŘIPOJENÍM VODY K VENTILU PROPLACHNĚTE VODNÍ POTRUBÍ.



1. IT IS NECESSARY TO CHECK FOR LEAKAGE BEFORE INSTALLATION TANK.
2. FLUSH BEFORE CONNECTING WATER TO VALVE WATER PIPING.

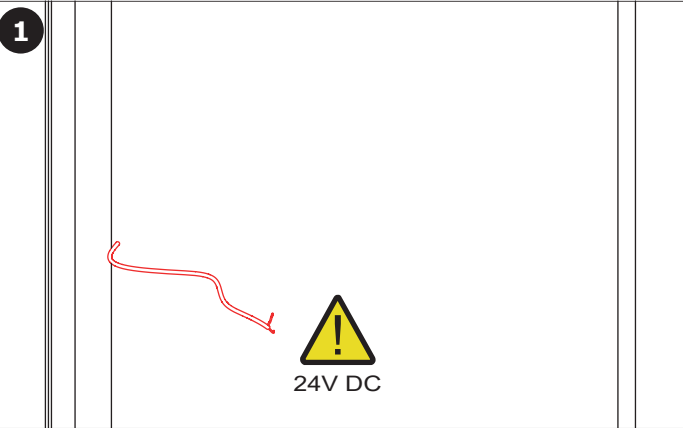

pouze pro SLW 02x a SLW 30x
only for SLW 02x and SLW 30x

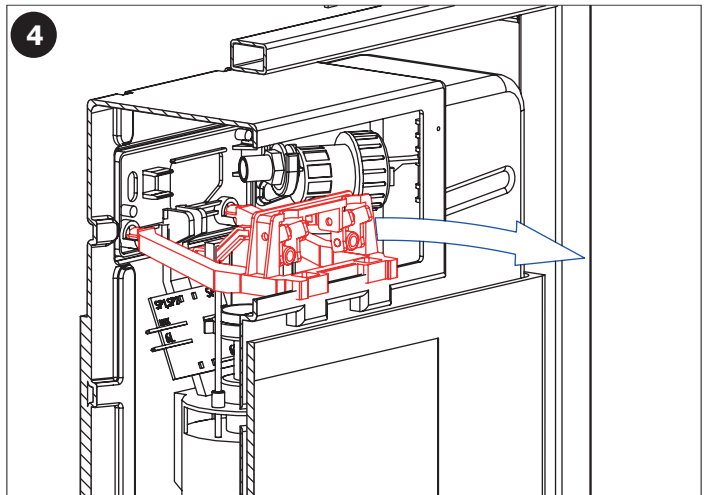
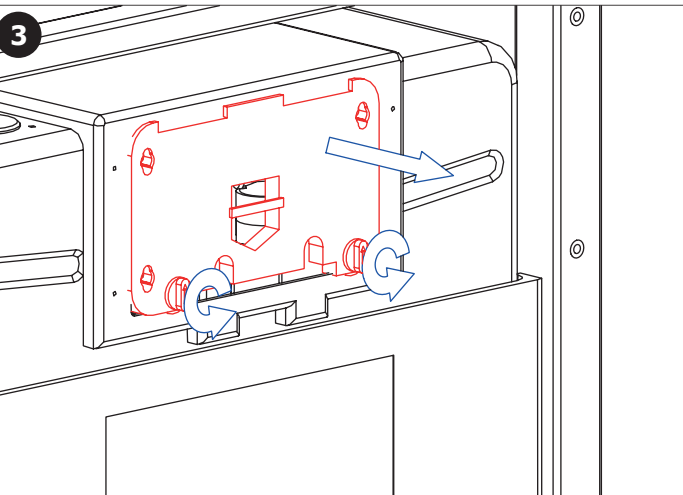
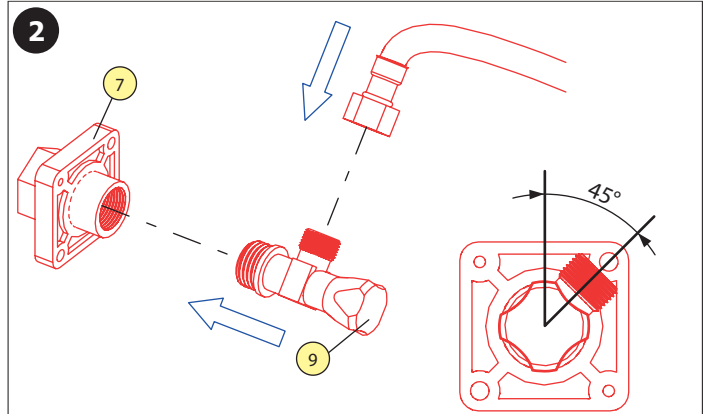

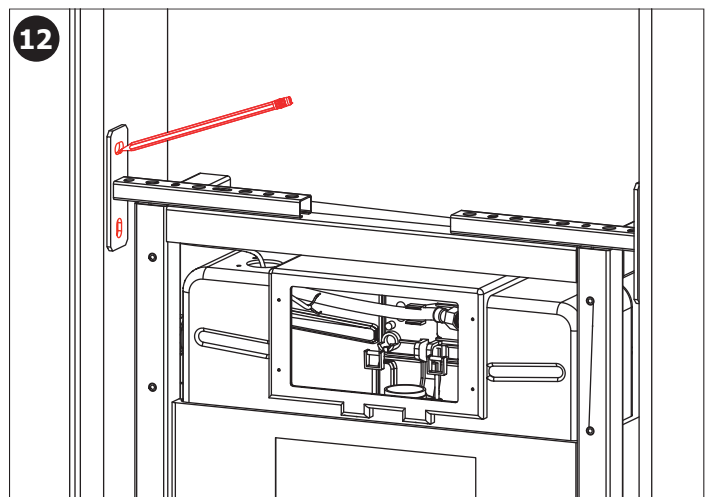
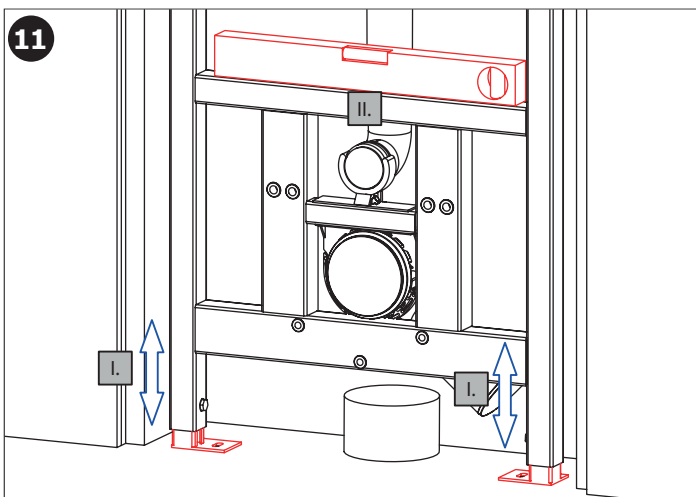
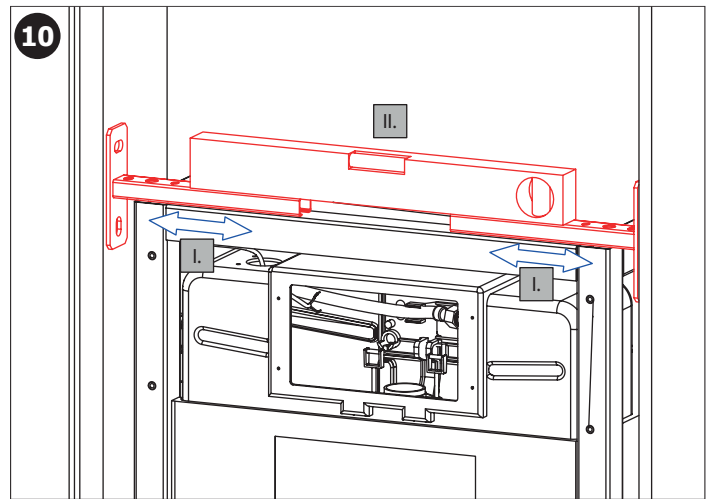
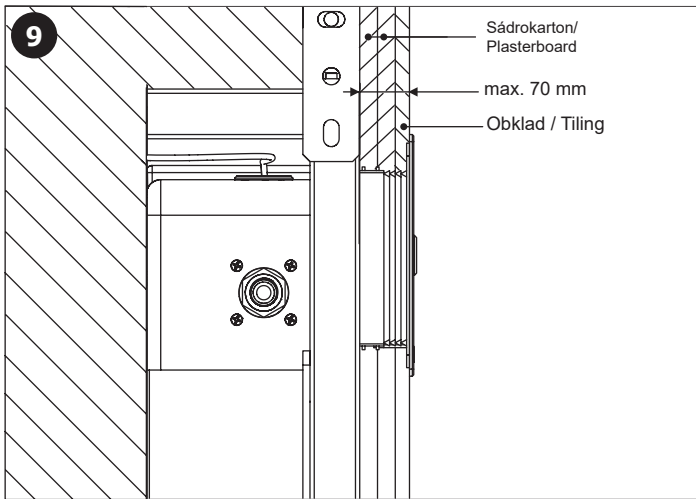
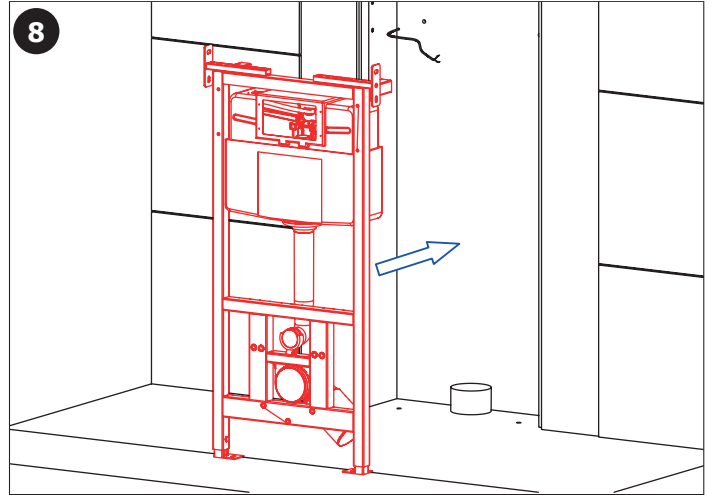
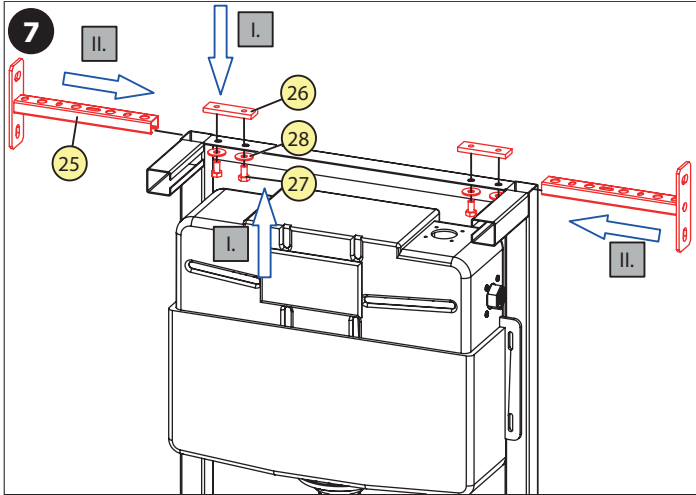
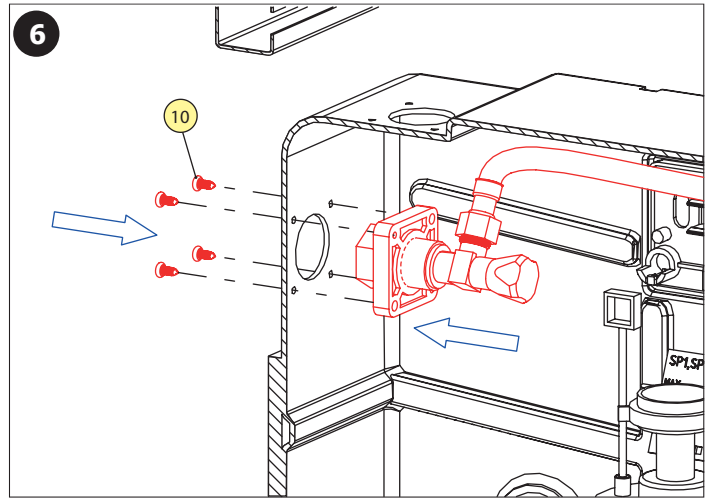
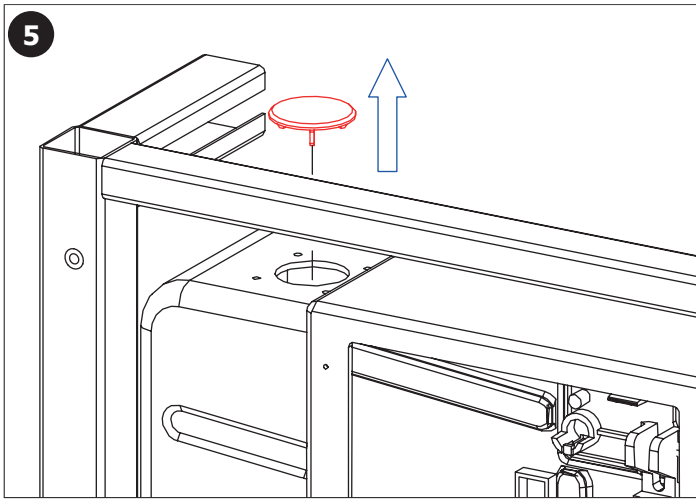

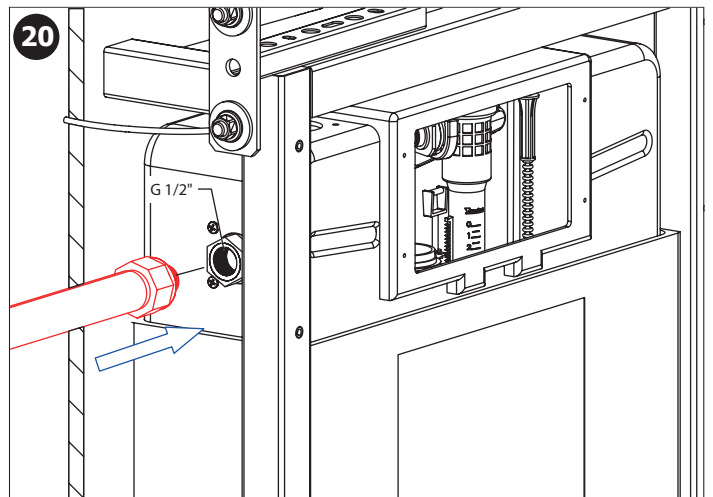
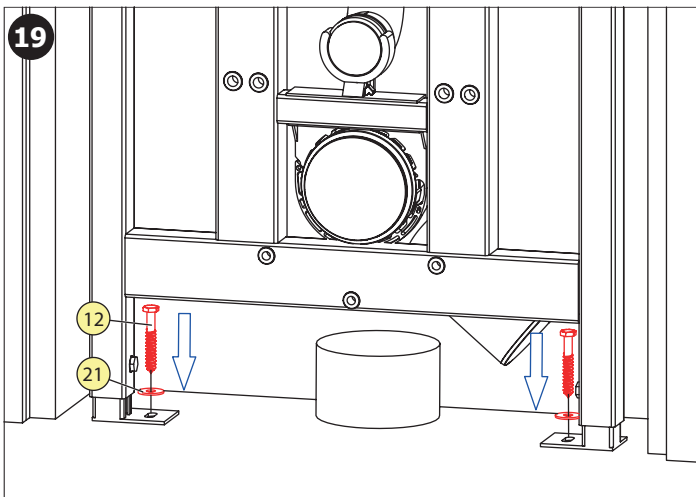
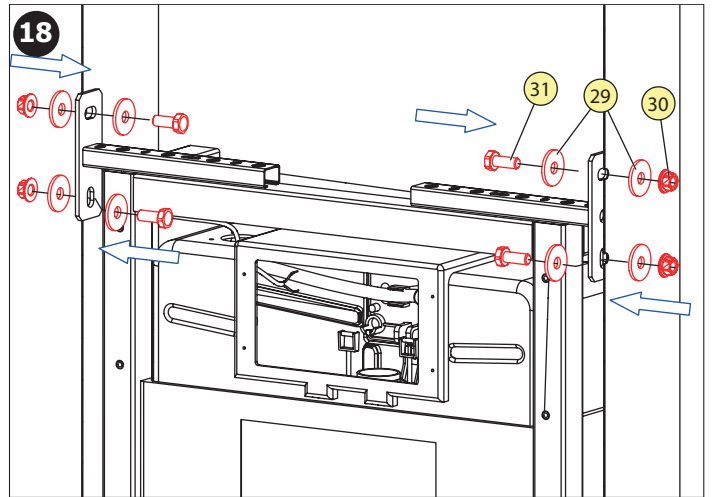
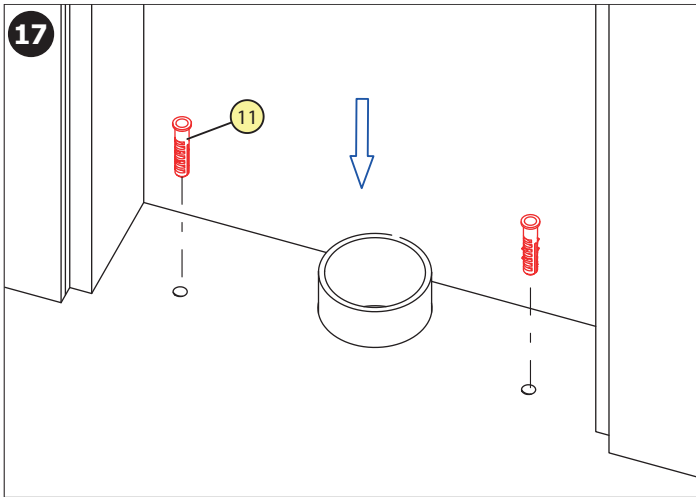
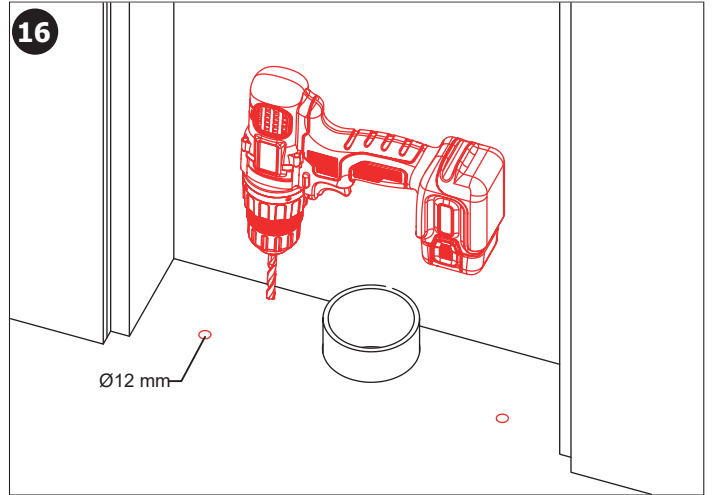
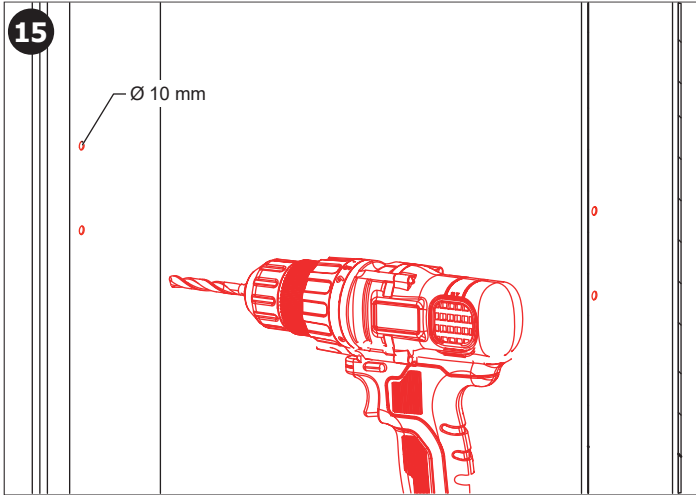
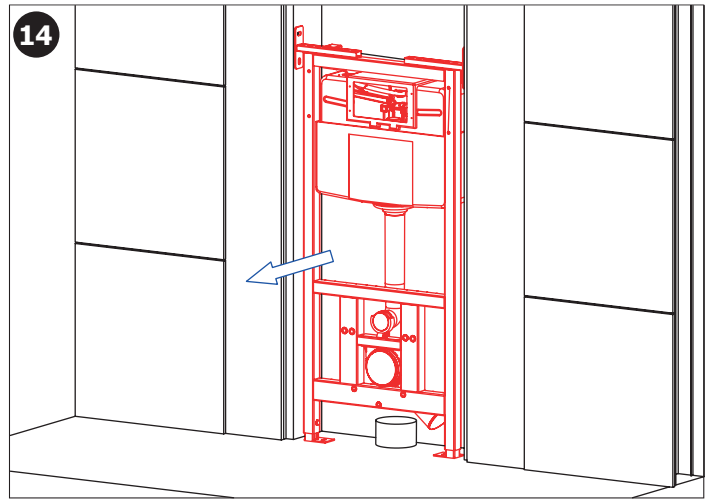
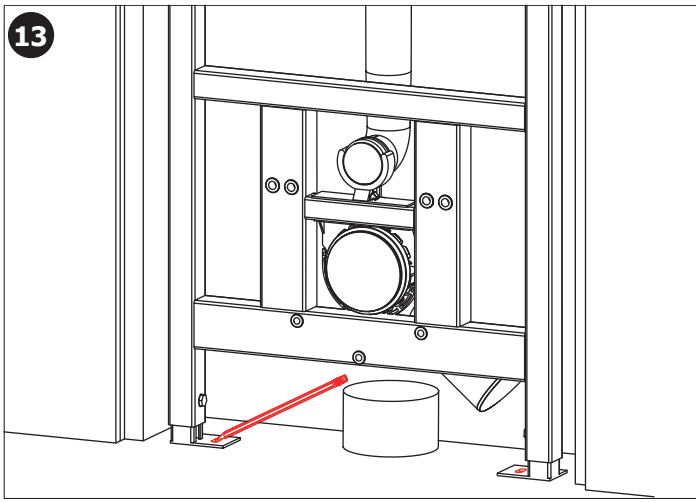

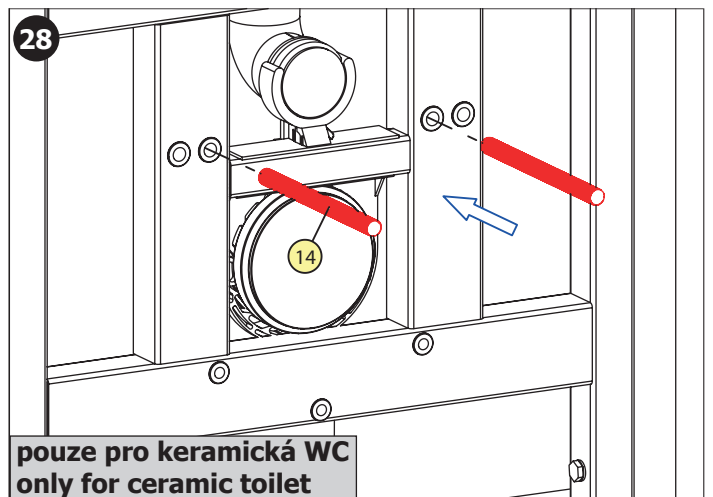
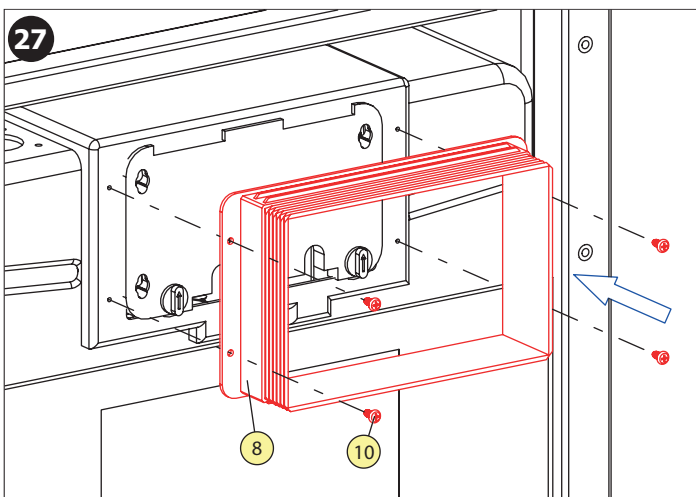
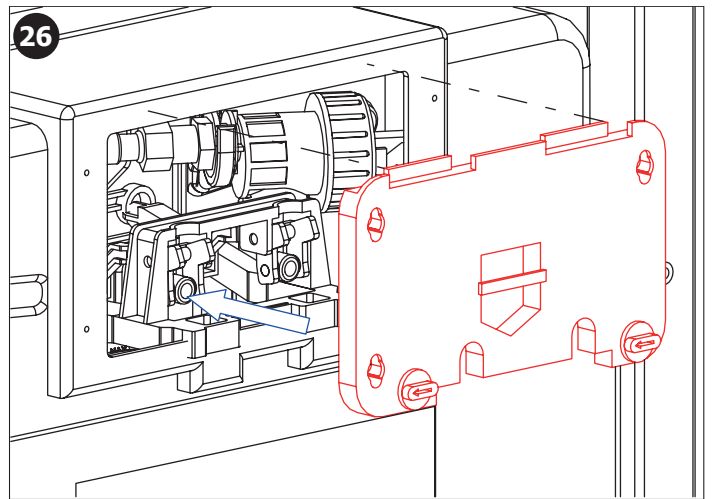
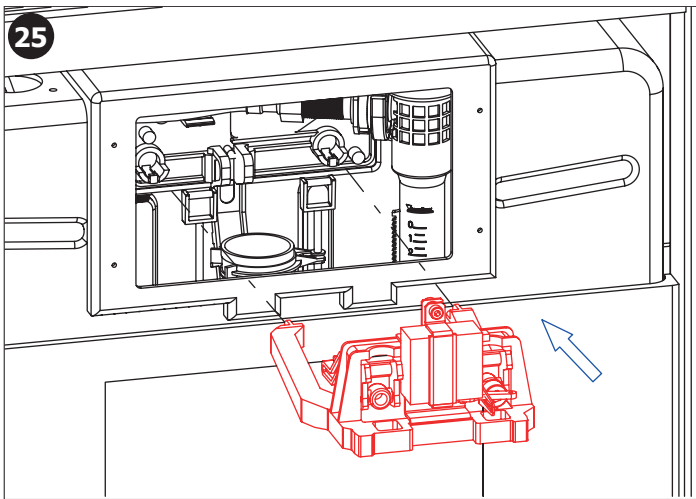
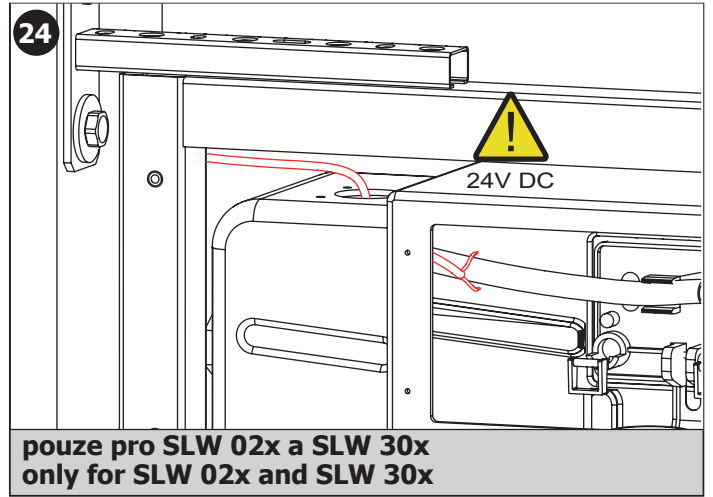
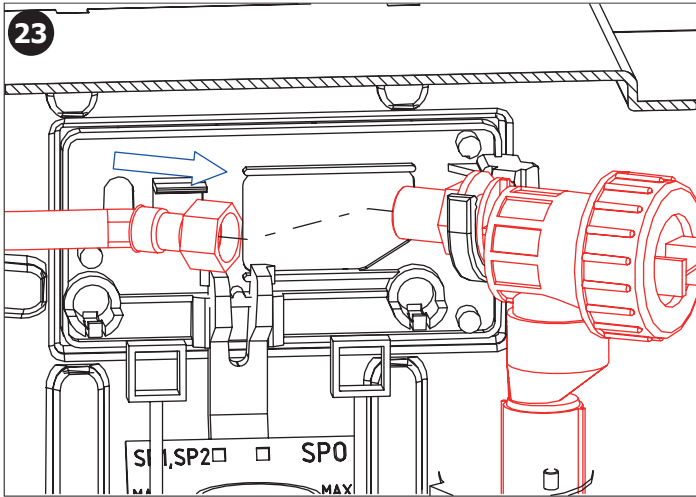
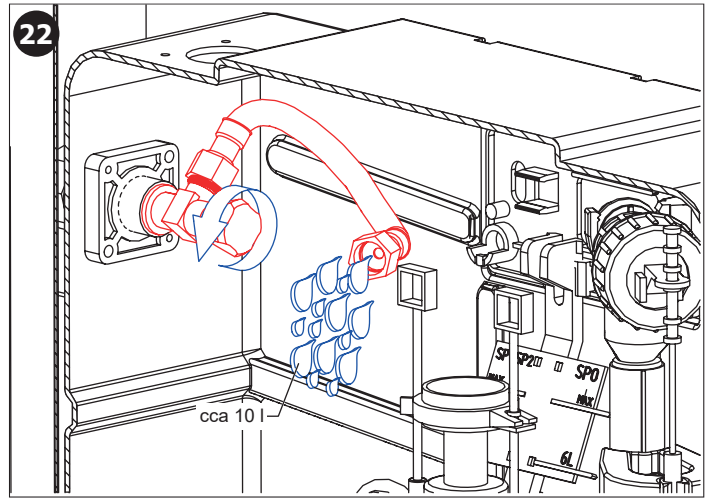
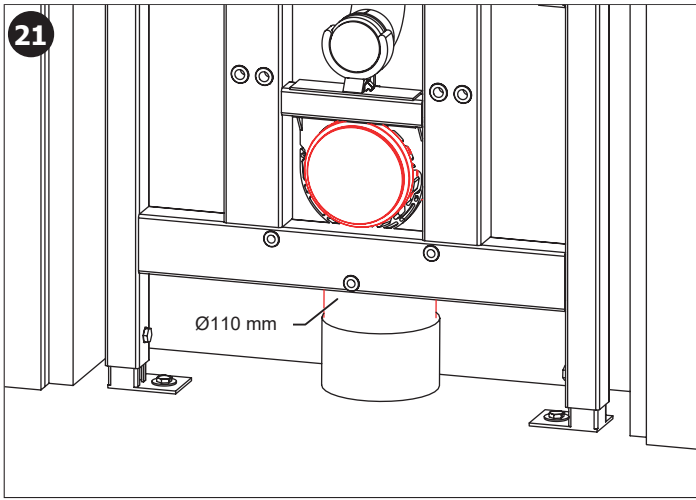

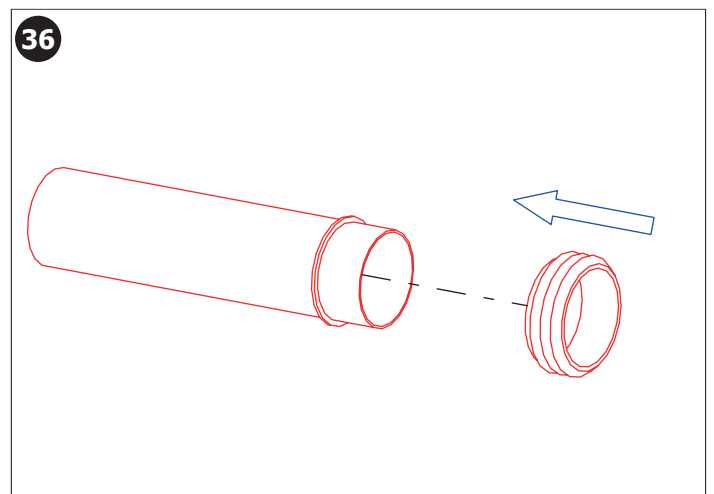
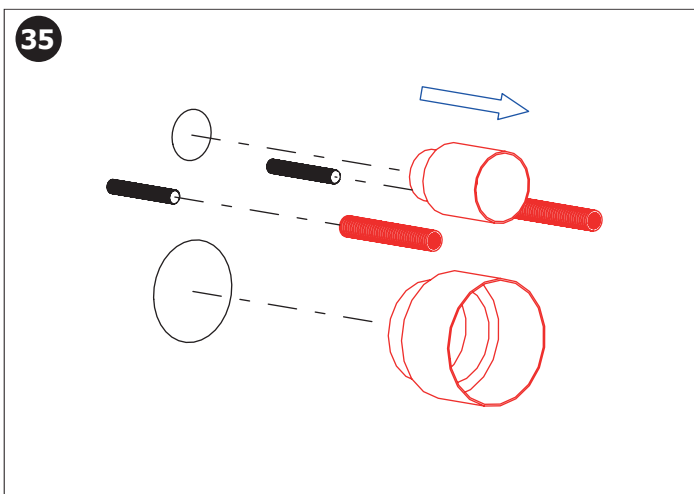
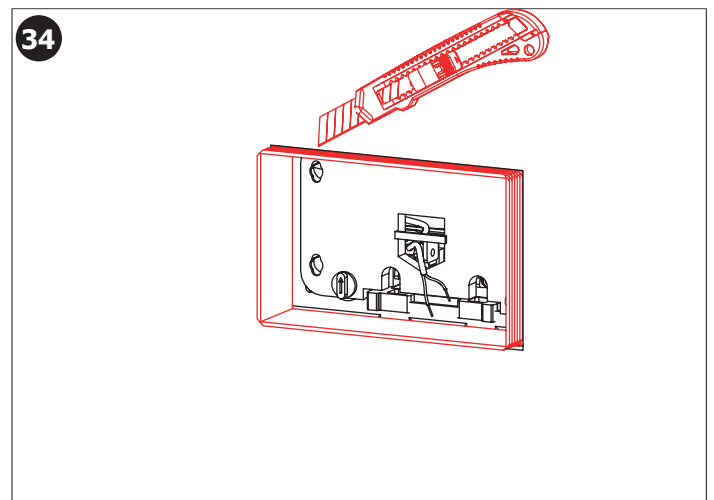
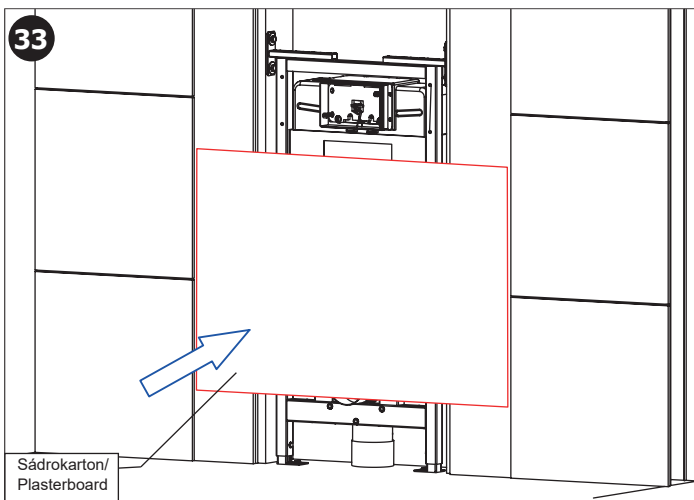
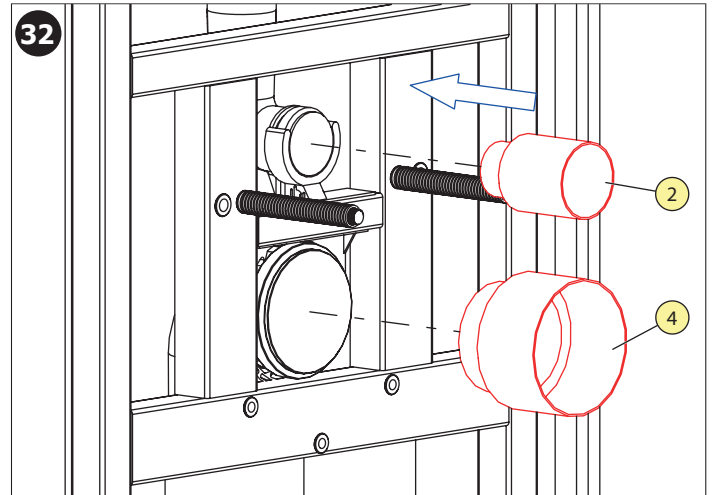
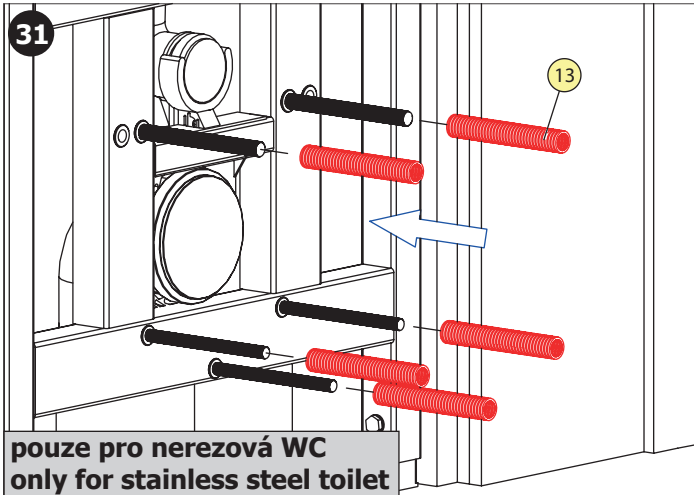
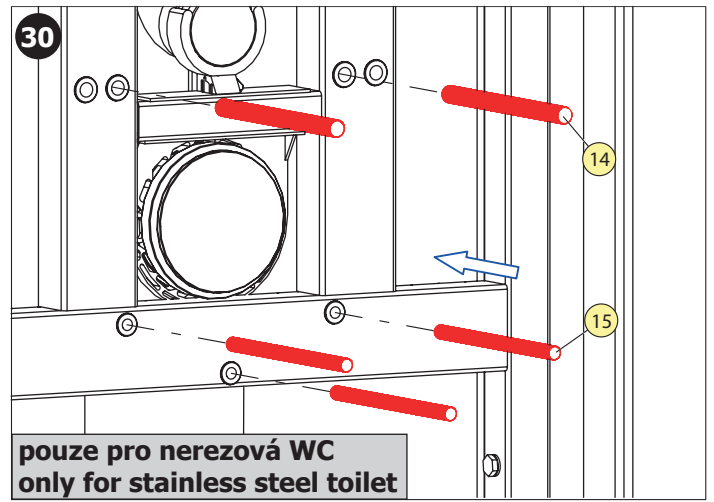
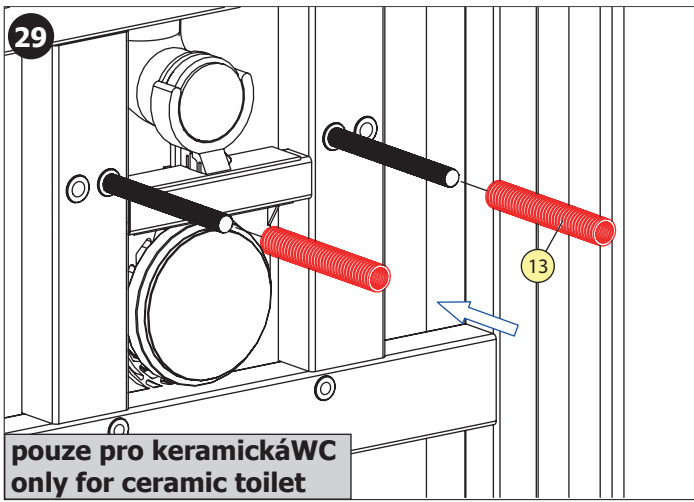

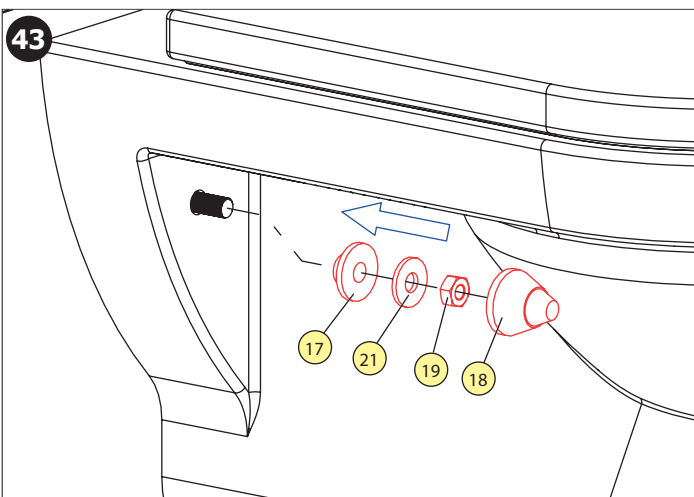
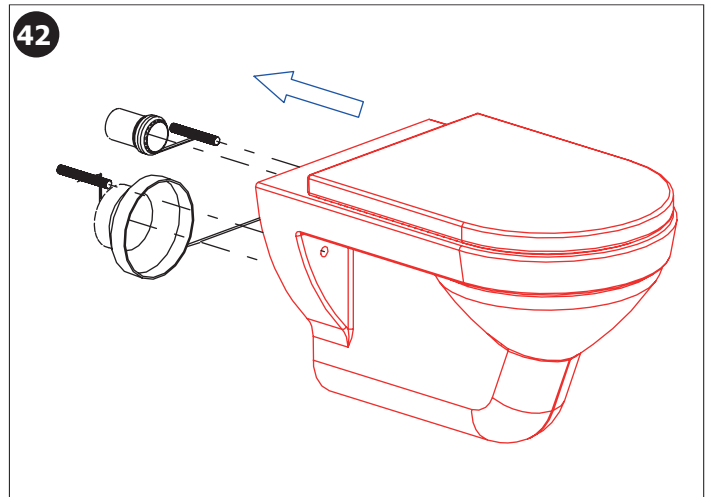
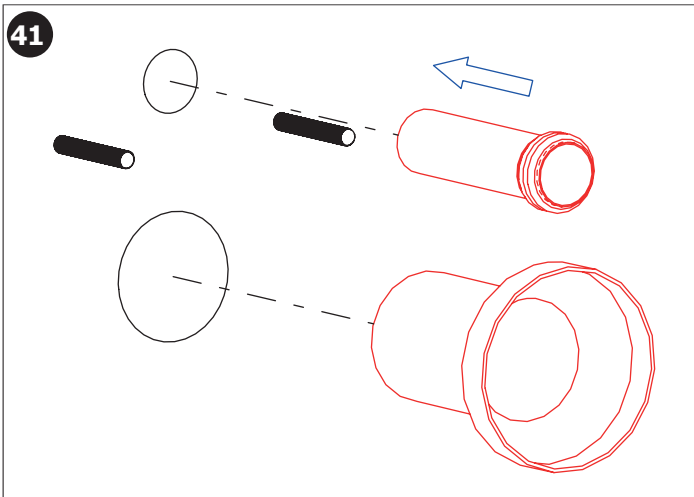
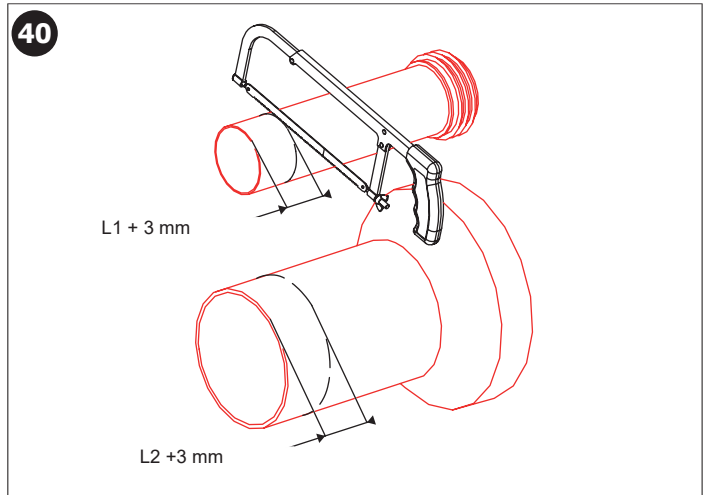
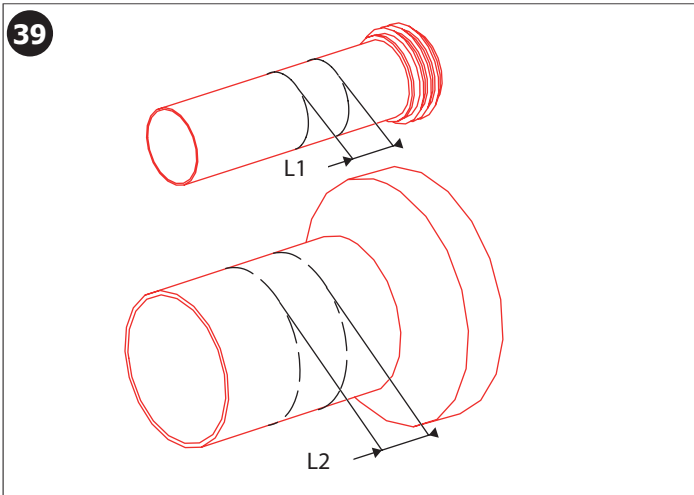
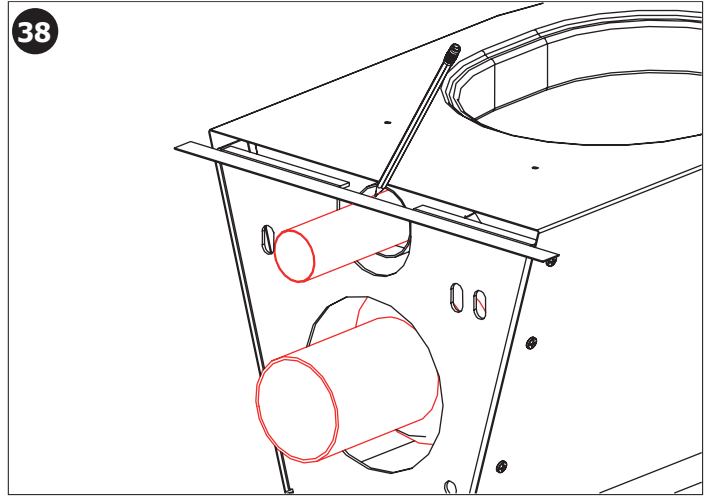
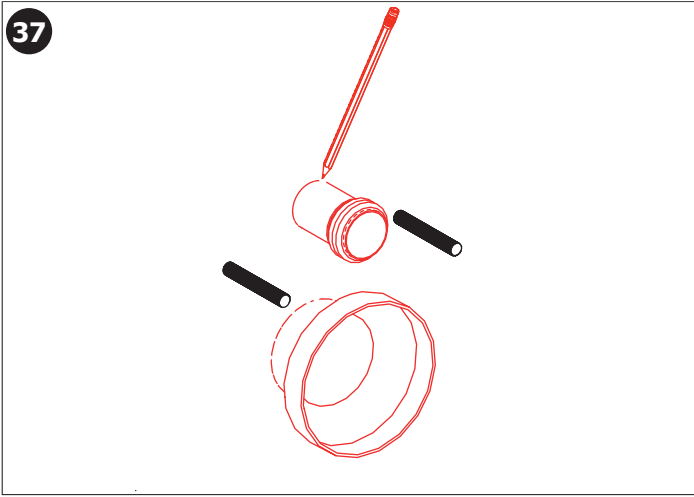

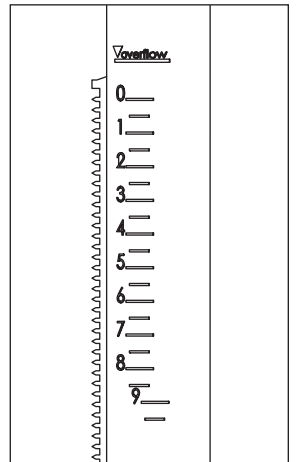
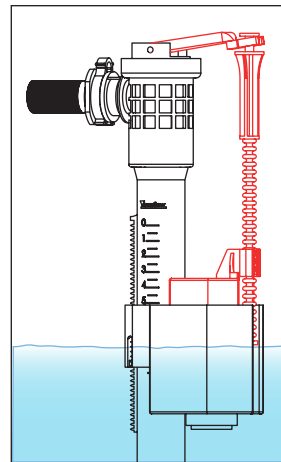
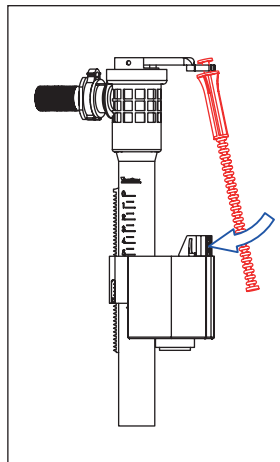
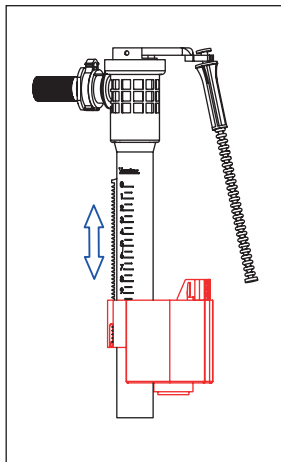
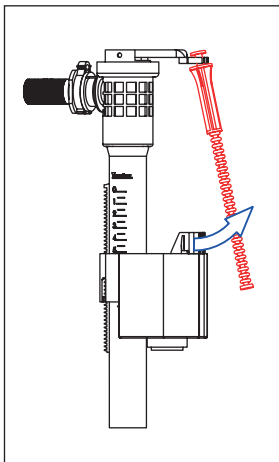
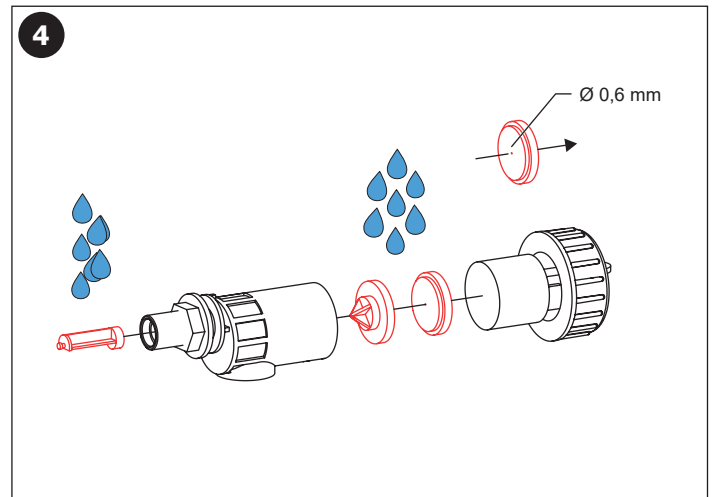
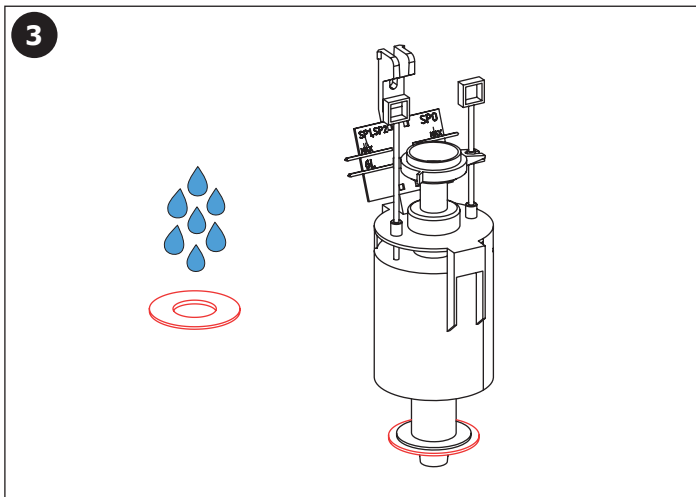
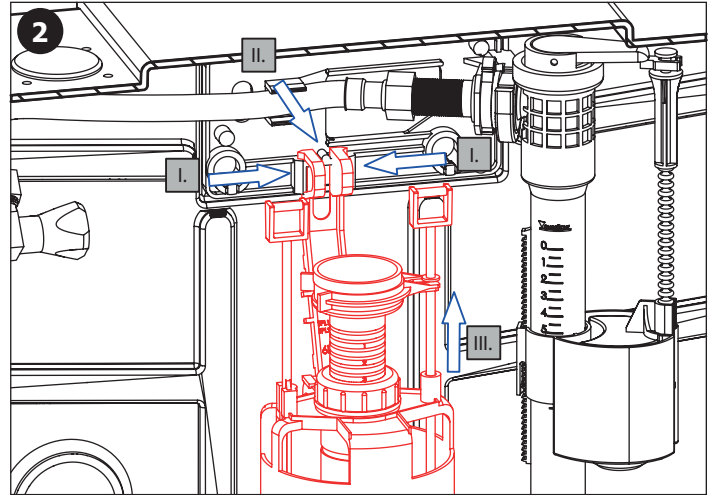
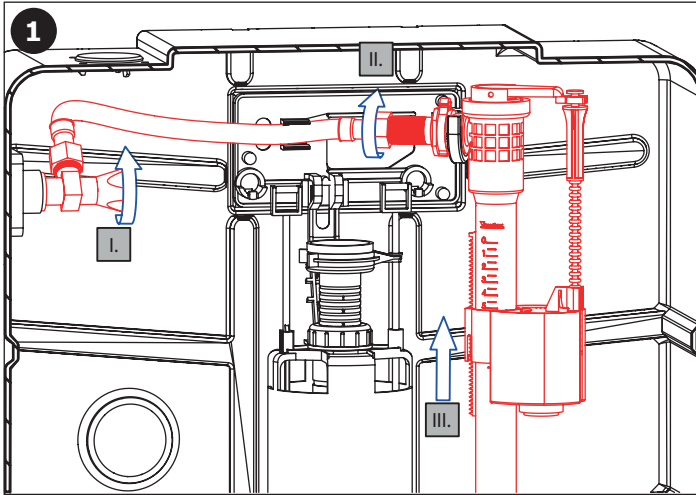

CS Nastavení splachovacího ventilu
SK Nastavenie splachovacieho ventilu
EN Flush valve adjustment
RU Регулировка сливного клапана

DE Einstellung des Spülventils
PL Regulacja zaworu spłukującego
RO Reglarea valvei de spălare
ES Ajuste de la válvula de descarga

FR Réglage du robinet de chasse
NL Spoelventiel instellen
LT Nuleidimo vožtuvu reguliavimas
HU Öblítőszepel beállítása

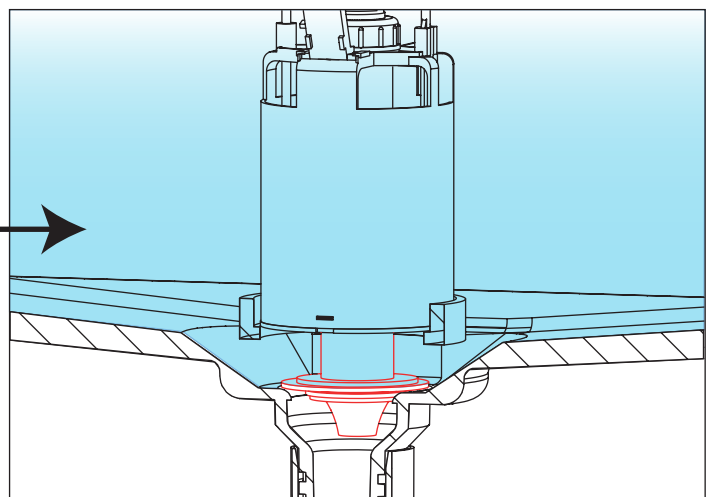
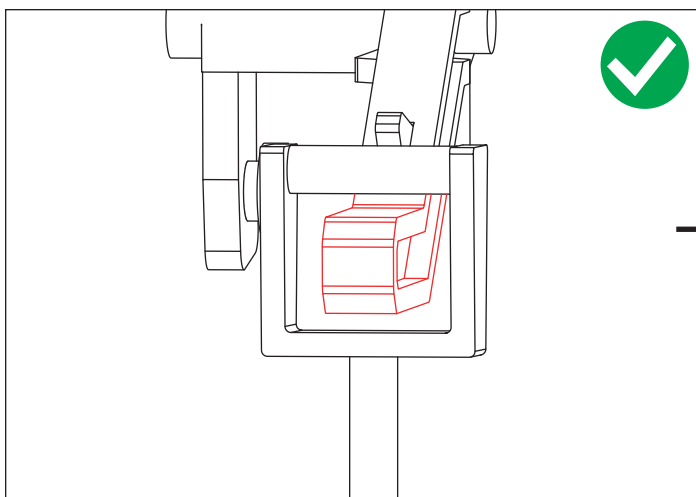
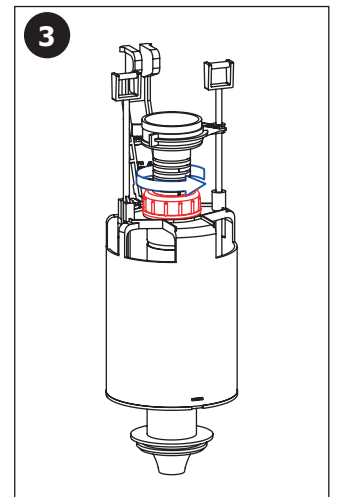
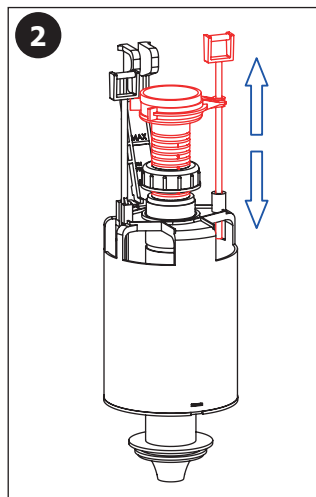
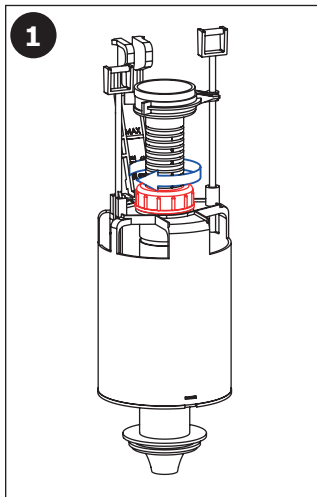
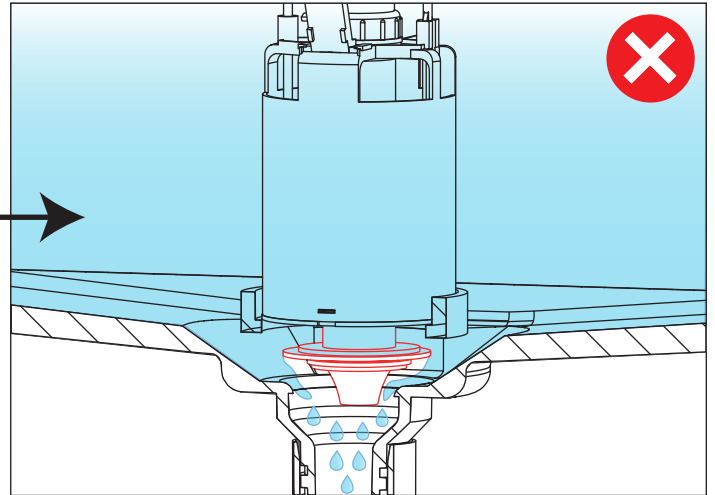
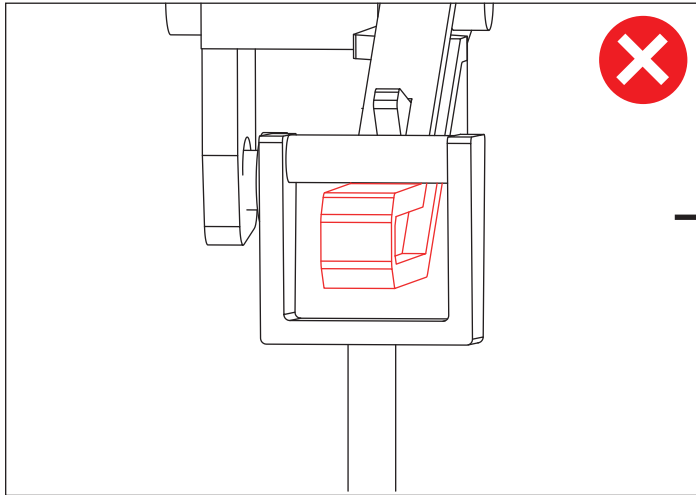

CS Další informace

RU Дополнительная информация

RO Mai multe informatii urmeaza

NL Meer informatie

SK Ďalšie informácie

DE Weitere Informationen

ES Más información

LT Daugiau informacijos

EN More information

PL Więcej informacji

FR Plus d'information

HU További Információ

CS

Po vybalení výrobku je nutné s obalem postupovat podle zákona o obalech.
Výrobce ujišťuje, že na výrobek je vydáno prohlášení o shodě v souladu se zákonem č. 22/1997 Sb. Společnost SANELA spol. s r.o. plní povinnost zpětného odběru, odděleného sběru, využití nebo odstranění výrobku s ukončenou životností dle platné legislativy - více informací na <https://www.rema.cloud/o-nas#sberna-mista>.

SK

Po vybalení výrobku je potrebné s obalom postupovať podľa zákona o obaloch.
Výrobca garantuje, že na výrobok je vydávané prehlásenie o shode v súlade so zákonom č. 22/1997 Sb.

EN

It is necessary to proceed according to the law about packaging material after unpacking of the product.
Producer assures that this product has declaration of conformity in accordance with the regulation 73/23/EHS and 92/31/EHS.

RU

Утилизация упаковочного материала должна производиться в соответствии с законом.
Производитель подтверждает, что у этого изделия есть Декларация Соответствия в соответствии с нормами 73/23/EHS и 92/31/EHS.

DE

Dies ist erforderlich auf der Grundlage der gesetzlichen Bestimmungen für die Rücknahme und/oder Entsorgung von Verpackungsmaterial.
Wir, SANELA spol. s r.o. erklären dass dieser Product ist in Übereinstimmung mit die nächste Norm: 73/23/EHS und 92/31/EHS.

PL

Po wypakowaniu urządzenia zaleca się postępować zgodnie z instrukcją obsługi.
Producent posiada na swoje wyroby deklaracje zgodności na podstawie przepisu c.73/23/EHS i 92/31/EHS.

RO

Gestionarea ambalajelor se va realiza conform legislației în vigoare.
Producătorul garantează că aceste produse au declarații de conformitate care respectă reglementările 73/23/EHS și 92/31/EHS.

ES

Después de desembalar el producto es necesario proceder con el embalaje en acuerdo con la ley de los embalajes.
El productor asegura que este producto tiene declaración de conformidad de acuerdo con la ley núm. 73/23/EHS y 92/31/EHS.

FR

Conformément à la loi, Il est nécessaire de se conformer à la procédure de déballage du produit.
Le fabricant garantie que ce produit est en conformité avec la réglementation 73/23/EHS et 92/31/EHS.

NL

Het is verplicht om de wet in acht te nemen betreffende het omgaan met verpakkingsmateriaal.
De producten worden geleverd met een verklaring van overeenstemming met 73/23/EHS en 92/31/EHS.

LT

Išpakavus produktą būtina laikytis taisyklių atsižvelgiant į medžiagą, iš kurios pagaminta pakuotė.
Gamintojas garantuoja, kad šis produktas turi atitiktis deklaraciją pagal reglamentą 73/23/EHS ir 92/31/EHS.

HU

Mindez elengedhetetlen a törvényi rendelkezések szerint a cseréhez vagy az alkatrészpótláshoz.
A SANELA s pol s.r.o. kijelenti, hogy ez a termék az alábbi normáknak megfelelően készült: 73/023/EEC és 89/336/EEC. pótalkatrész biztosításához.